



SPEKVA 藝

INSTALLATION

CONTENTS

03	Before installation	08	Sinks and pipes
04	Taking delivery and storage	08	Worktop overhang, radiators and cavities
04	Jointing of tops	08	Brickwork and cavities
05	Installation	09	Cut-outs, hobs and cookers
05	Worktops with a downstand front edge	09	Moulding strips
06	Worktops with a side piece	09	Breakfast bars
06	Worktops using the Lamello- / Unoflex system	10	Installation examples
07	Installing SPEKWALL	11	Installation examples
07	Installing end grain worktops	12	Kontakt
07	Sources of heat or moisture		

By choosing FSC®-certified wood products, you are helping manufacturers to attain a positive and sustainable balance with the environment. Amongst the requirements for an FSC certification it stipulates that a minimum of one tree should be planted for every tree felled. At SPEKVA we are highly conscious of the environment. Our worktops are treated exclusively with oil and we do not use any toxic hardening agents. SPEKVA's oils contain no toxic heavy metals, parabens, phtalates or other dangerous substances.





Our unique joints (Prima, Classic and Royal) have an extra glue face of up to 40 per cent, which significantly reduces the risk of splitting.

BEFORE INSTALLATION

Wood is a natural material. Care is required when installing the worktop. If you follow these instructions, the worktop will be easy to look after and it will keep its excellent properties for many years to come. SPEKVA provides a 30-year guarantee on all worktops with tongue and groove joints (Prima, Classic and Royal). There is a two-year guarantee on integrated accessories such as sinks and spotlights.

The guarantee applies to faults in manufacturing or materials on the condition that the products have been correctly installed and maintained. There is no guarantee on solid wood tops with mitred joints.

Where a complaint is justified, it will be rectified free of charge. We will however charge for unnecessary visits or where the complaint is unjustified. Our service technicians will where possible provide a quote for rectification of errors where a complaint was not justified.

SPEKVA is not liable for costs in connection with delayed delivery or missing items. For more information about our products and guarantees, please see SPEKVA.dk. There are guides for maintenance and repair at SPEKVA.dk/en/downloads and video guides on youtube.com/SPEKVA

TAKING DELIVERY AND STORAGE

Always check that the packaging is intact and that there are no discrepancies between your order and the consignment note. If there are no comments on the consignment note, we will consider the items as approved by the recipient.

The worktop must be installed no later than eight days after receipt. Keep it in its packaging material until installation. The worktop should be stored horizontally on a level surface and in the room where it is to be installed for at least 48 hours.

For at least four weeks prior to installation, the room must have been well ventilated and heated to approximately 20°C, with a humidity level of between 40 and 60 per cent.

SPEKVA does not cover the costs of dismantling/reinstallation in the event of a complaint.

⊗ **The worktop can expand or contract by 5 mm over a depth of 600 mm in response to changes in humidity and room temperature. It is therefore important to allow space either at the front or back edge, with 5 mm at the joint where the depth is 600 mm.**

JOINTING OF TOPS

If the worktop is to be attached to a cabinet with a top, it is important to create cut-outs in the unit top corresponding to each bracket. This allows for subsequent tightening of the worktop from underneath.

Apply a thin strip of glue as supplied in the service box along each of the surfaces in question. The glue will keep the joint tight.

⊗ **Do not use silicone. Install the brackets and tighten so that the joints are completely tight. Immediately remove excess glue with a damp cloth.**

If the surfaces are River Washed, then let the glue dry for approx 30 mins and then peel it away instead of using a damp cloth. Otherwise the glue will dry within the grain and it will be very difficult to remove.

At the factory, a tongue is placed in the groove on the first slab to counteract warping in the joint.

INSTALLATION

The worktop must always be both supported and tightened into place. Install batons where there is no unit to support the worktop.

Fasten the worktop with three rows of screws across the front edge, middle and back edge. Ensure a distance of no more than 600 mm between each screw in the longitudinal direction of the worktop.

Use screws with washers for the centre pre-drilled holes. Tighten the worktop at the rear edge, but do not tighten the screws to the extent that the wood cannot expand and contract naturally. If the depth of the worktop is greater than 800 mm, the drill holes should be \varnothing 15 mm.

If there is no top to the cabinets, use the angle brackets supplied at the middle of the unit sides.



WORKTOPS WITH DOWNSTAND FRONT EDGE

Worktops with a downstand front edge must be supported by means of the batons supplied. Install the batons at the rear of each unit and at each worktop joint, for example at corner slab joints. Drill holes measuring \varnothing 10 mm at the front edge and \varnothing 5 mm at the back edge corresponding to the batons.

Install the angle brackets supplied in the middle of the batons and tighten the worktop at the front edge, middle and rear edge.

WORKTOPS WITH A SIDE PIECE

The side panel base edge end of timber has 6 mm adjustable feet to protect the timber from drying out where there is underfloor heating, or water penetration such as from washing the floor. It is important that worktops with a side piece are supported by units or side walls.

✘ **Worktops with a side piece cannot support cabinets.**

Fasten the worktop and side piece with three rows of screws at the front edge, middle and back edge. Ensure a distance of no more than 600 mm between each screw in the longitudinal direction of the worktop. Insert screws with washers into the centre of the 10 mm holes and screw up into the worktop. Do not tighten the screws to the extent that the wood's natural expansion and contraction is prevented. If the depth of the worktop is greater than 800 mm, the drill holes should be Ø 15 mm and there should be several rows of screws over the depth of the worktop. A rule of thumb: 1 screw per 200 mm.

WORKTOPS USING THE LAMELLO (DOWEL) AND UNOFLEX SYSTEM*



These worktops are fitted with hardware.

- 01 Apply the glue on the relevant side piece surfaces.
- 02 Press the slabs together. Tighten the brackets with the Allen key supplied. Remember to re-tighten.
- 03 Install side walls or brackets where applicable.
- 04 Immediately remove any excess glue with a damp cloth.

✘ **Unoflex system elements should be glued as soon as possible after delivery.**

INSTALLING SPEKWALL

Mark the wall to correspond with the steel reinforcement bars in the back of the wall cladding. Drill holes, insert Rawlplugs and screw the screws into the top holes. Screw the magnets supplied in the rest of the holes (remember Rawlplugs). Place these to correspond with the magnets in the steel reinforcement bars.

Hang SPEKWALL on the screws and allow it to click into place on the magnets. It will now be quite secure at the top. The magnets allow for expansion and contraction of the wall cladding, but will not allow it to move off from the wall.



INSTALLING END GRAIN WORKTOPS

Fasten the worktop with three rows of screws across the front edge, middle and back edge. Ensure a distance of no more than 600 mm between each screw in the longitudinal direction of the worktop. Use screws with washers for the centre pre-drilled holes in the unit top.

Pre-drill with a 3 mm drill piece in the underside of the worktop. Tighten the worktop at the rear edge, but do not tighten the screws to the extent that the wood cannot expand and contract naturally. If there is no top to the cabinets, use the angle brackets supplied. Drill a 10 mm hole in the angle brackets and affix to the middle of the unit sides.

SOURCES OF HEAT OR MOISTURE

Use the self adhesive aluminium foil (supplied in your service box) and position it to the underside area of the surface worktop. Over sources of heat such as dishwashers, stoves and radiators.

- ✘ **Without this barrier layer, the worktop will suffer from the effects of heat and vapour.**



SINKS AND PIPES

Sinks and water pipes should not be positioned near worktop joints and they should be positioned to allow a minimum of 200 mm to an edge. Cut-outs should be 5 mm larger than the item. When installing a double sink, it is important that a support is provided between the two parts of the sink.

- ✘ **The distance between two separate sinks must be at least 200 mm.**

WORKTOP OVERHANG, RADIATORS AND CAVITIES

To avoid warping, worktops with an overhang greater than 200 mm over their depth and 400 mm longitudinally must always be reinforced on the underside, either with a side wall or by fitting a metal reinforcement piece.

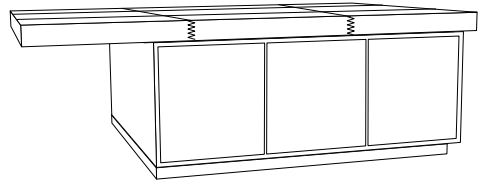

200 mm – 400 mm overhang.

- ✘ **The worktop must always be supported – also in window frames.**

BRICKWORK AND CAVITIES

- ✘ **Walls must be entirely dried out before installing worktops.**

Remember to establish a 5 mm airflow gap between the worktop and wall – including where you are installing a back wall. Always install aluminium foil between the edges of the worktop and the back wall and the brickwork. The shiny side of the foil must always be turned towards the wall in order to keep damp and cold from the worktop.

On a brickwork cooking island, allowance must be made for a 5 mm airflow gap beneath the worktop. Use 5 mm wedge strips between the brickwork and worktop. Gaps must be left between the strips so that airflow can reach below the worktop. Where a cavity is formed, the underside of the worktop must be dressed with aluminium foil and airflow must be ensured. Attach the aluminium foil using the glue supplied before installing the worktop.

CUT-OUTS, HOBS AND STOVES

Always cut from the underside of the worktop to avoid cuts and scratches in the surface of the wood. Cut-outs should always be 5 mm larger than the item so that the worktop has room to expand or contract.

Ensure tightness by sealing around cut-outs with sufficient caulk or acid-free silicone. Lack of tightness may result in splitting or discolouration of the wood, which is impossible to repair. Dress the seal with a strip of aluminium foil. Immediately remove any excess caulk with a damp cloth.

Stoves and hobs must be at least 200 mm from worktop joints and open worktop ends. They must be at least 100 mm from closed joints/end edges and at least 60 mm from the front edge.

Worktops abutting free-standing stoves must be sealed with caulk and aluminium foil. When inserting double hobs, the distance must be at least 200 mm to ensure that the wood does not dry out excessively, resulting in cracks.

Even sealed worktops may develop minor cracks. These should be seen as a natural consequence of heat; however, in order that cracks do not develop further, they should be treated immediately with SPEKVA care products.

✘ **SPEKVA oils are free from toxic heavy metals, parabens, phtalates and other dangerous substances.**



LOOSE MOULDING STRIPS

Loose moulding strips should be set in caulk or acid-free silicone. Use small tacks or screws as extra fixing.

BREAKFAST BARS

The breakfast bar comes with 6mm high adjustable feet underneath to enable airflow. It is placed loose on the worktop and must be maintained in the same manner on both sides (top and bottom) to ensure that it remains even. See our maintenance guide for further information.

INSTALLATION EXAMPLES

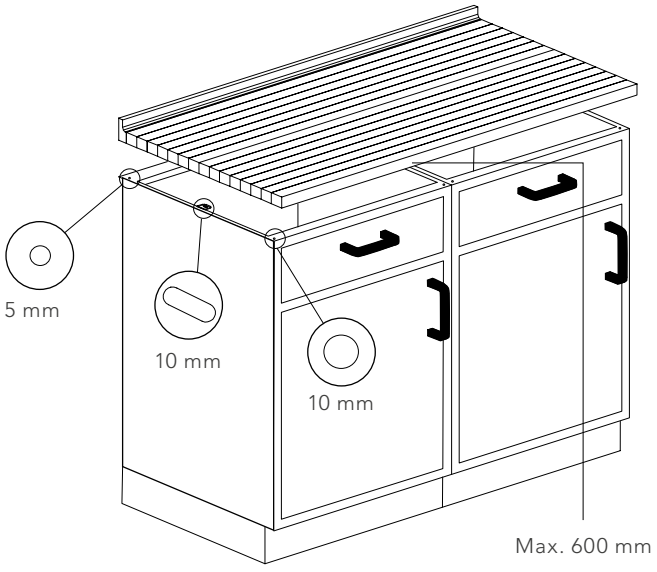

Thick line: Fixed edge

Arrow: Expansion/contraction allowance

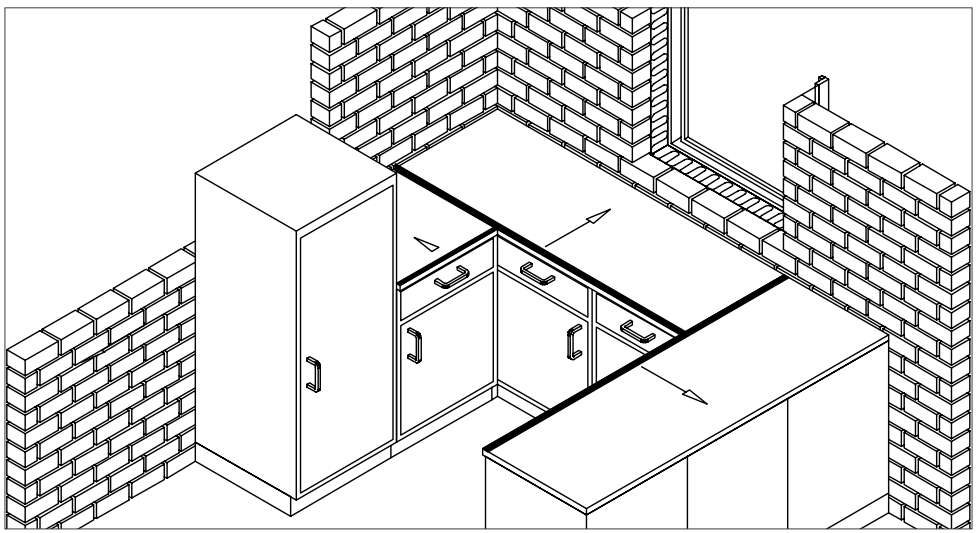

INSTALLATION EXAMPLES



Thick line: Fixed edge

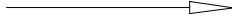

Arrow: Expansion/contraction allowance

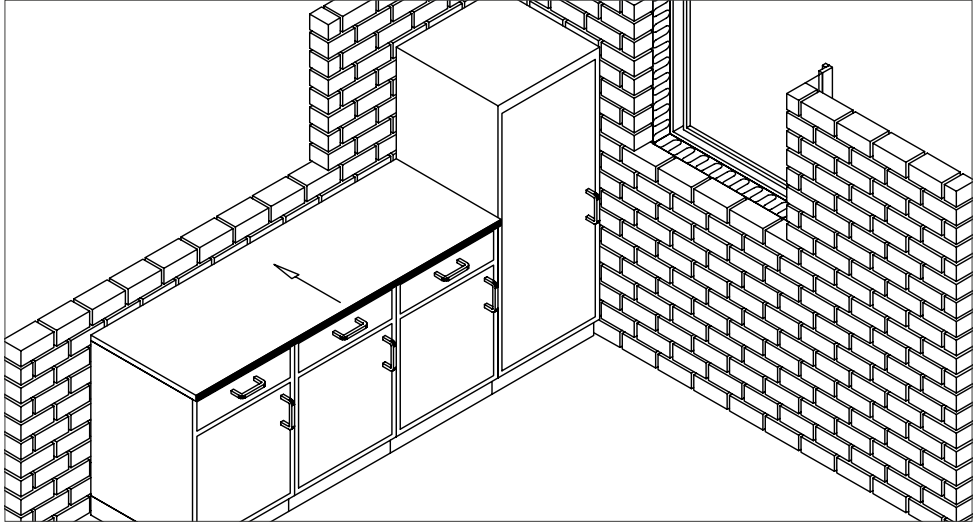

Thick line: Fixed edge



Arrow: Expansion/contraction allowance

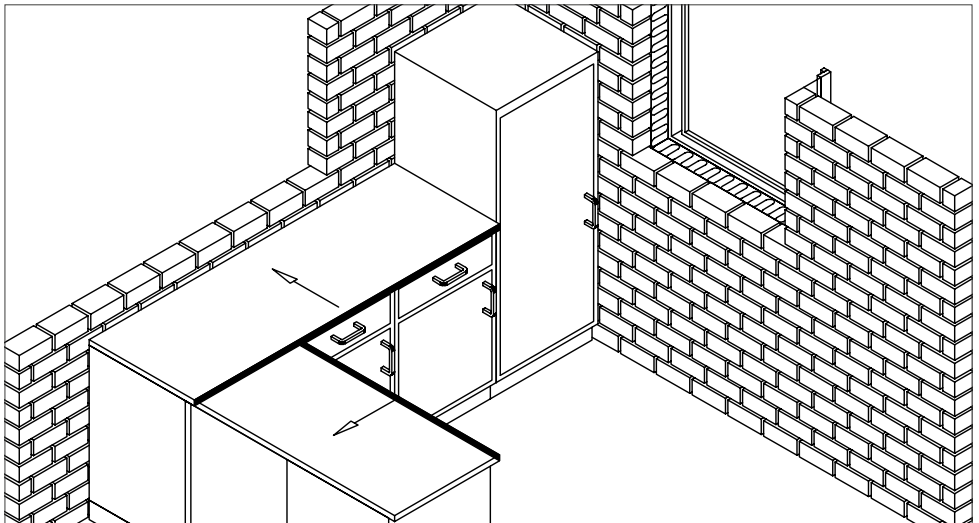



SPEKVA A/S

Kaermindevej 2
DK-6580 Vamdrup
Denmark

T +45 75 58 25 11
E spekva@spekva.dk
W spekva.dk

 [SPEKVA A/S – World](#)

 [@spekva](#)